



NNR05 Workshop
SPring-8, December 02, 2005



LEPS GeV-MeV photons for quark nuclear physics

S. Daté

for the LEPS Collaboration

(Accelerator Division, SPring-8/JASRI)



The SPring-8 site

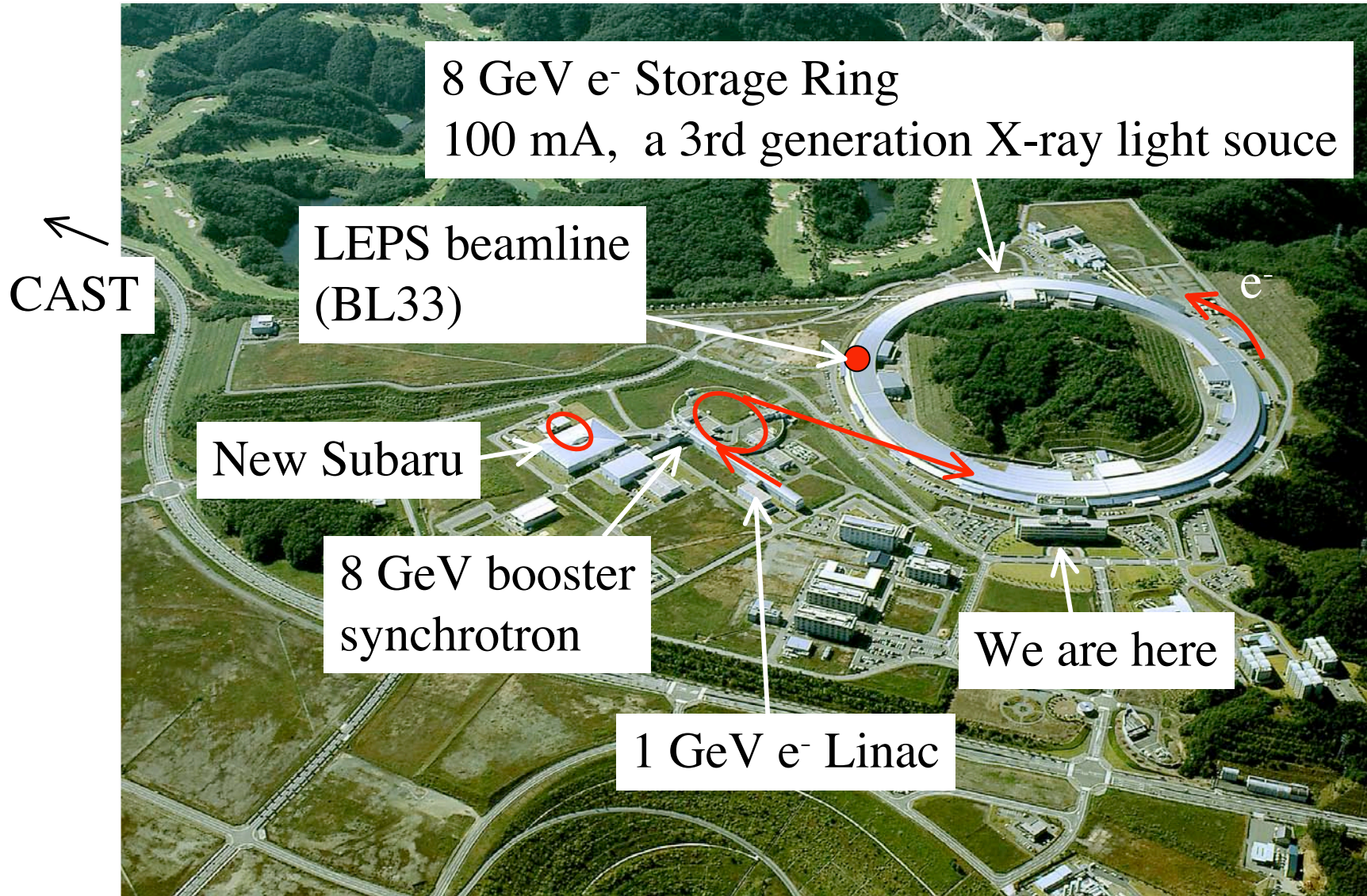



SPring-8 Beamline Map

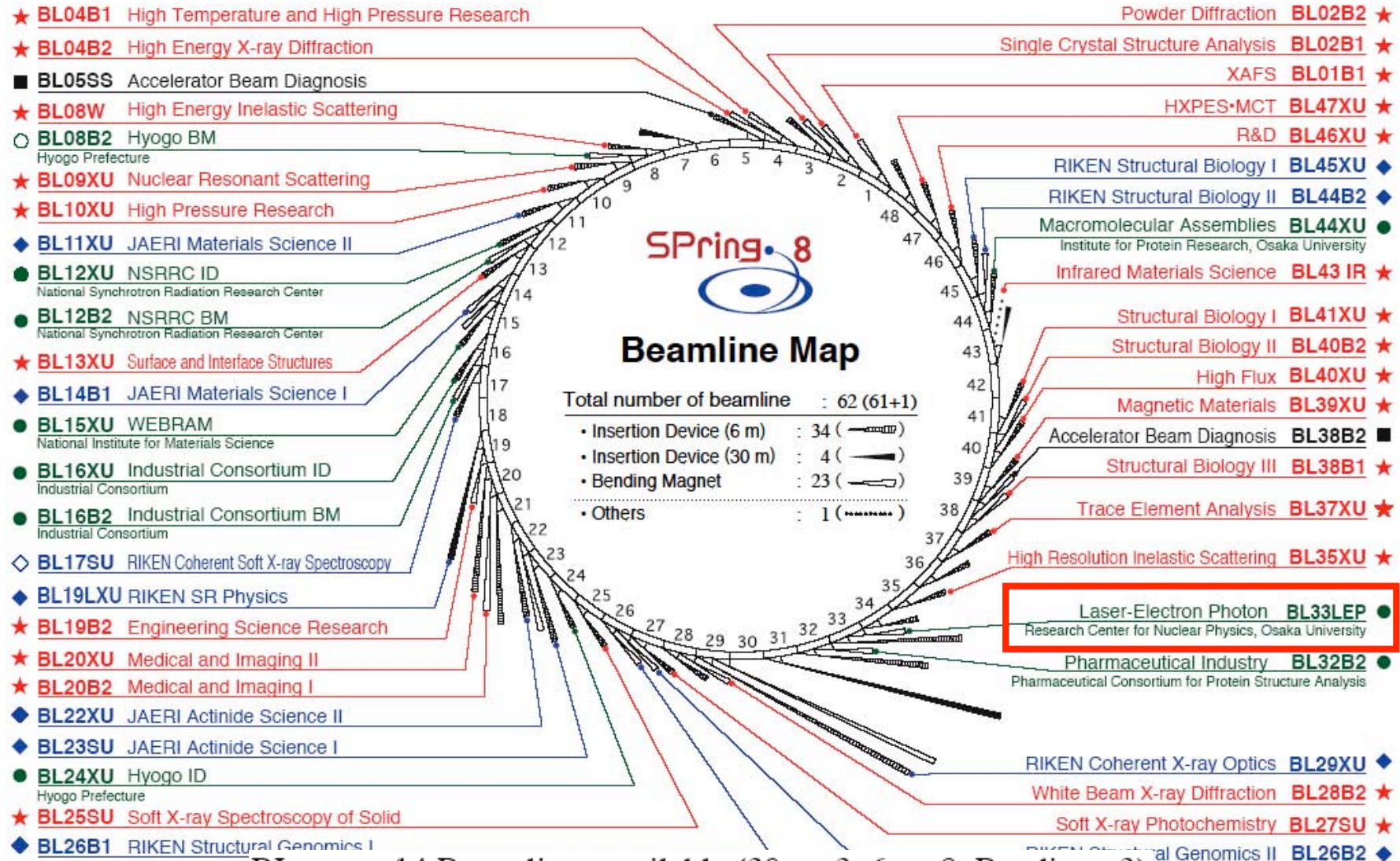

BL status: 14 Beam lines available (30m x3, 6m x8, Bending x3)



Construction of the LEPS BL



- Dec. 1995 Approved by Advisory Committiee
- Aug. 1996 BL33B2 was assigned to LEP
- Nov. 1997 Construction started
- Apr. 1999 First extraction of LEP
- Dec. 2000 First physics run



Schematic view of the LEPS facility

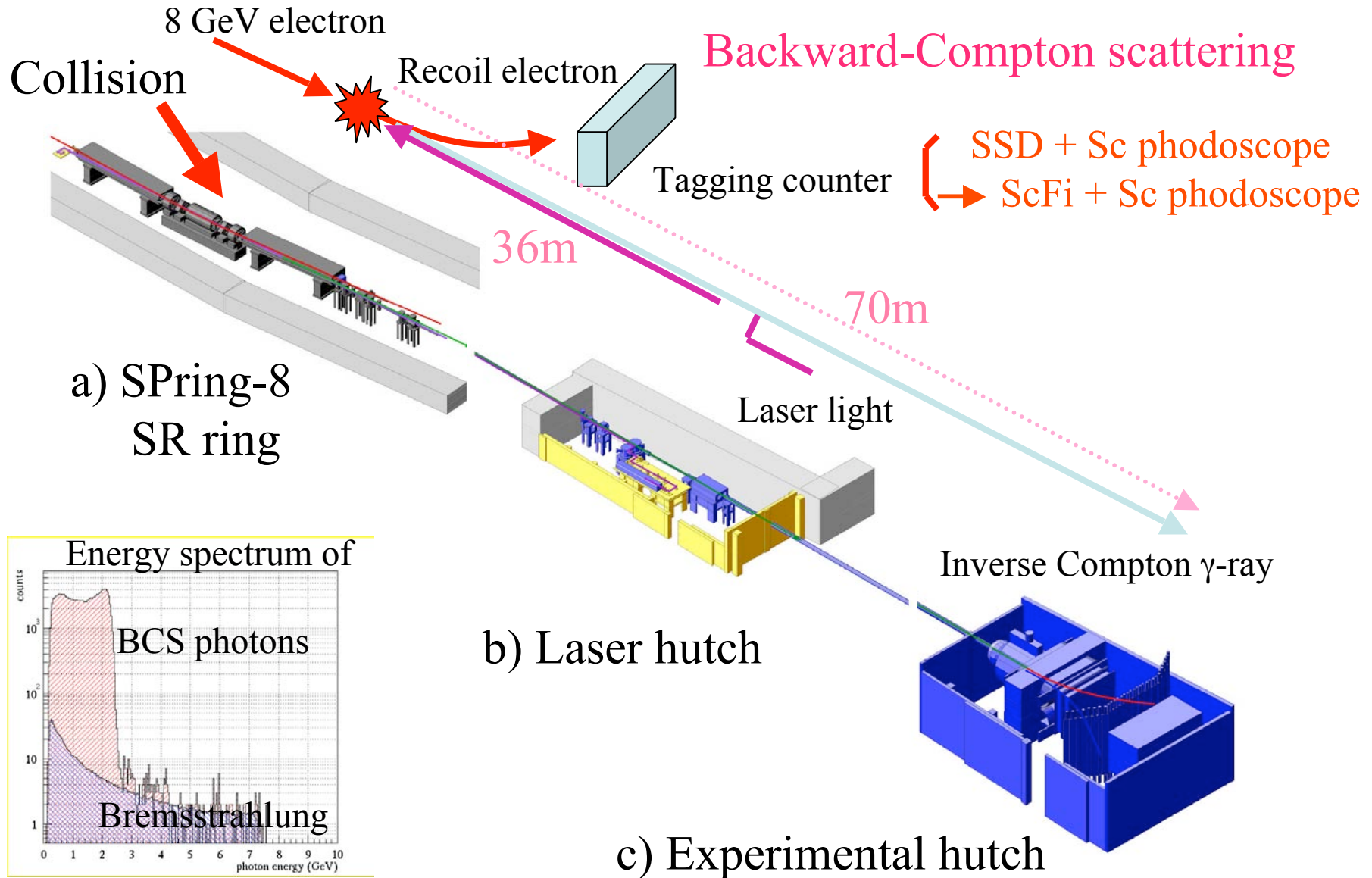



The LEPS Collaboration

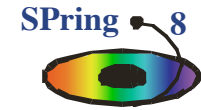

Research Center for Nuclear Physics, Osaka University : T. Nakano, D.S. Ahn, M. Fujiwara, K. Horie,
T. Hotta, K. Kino, H. Kohri, N. Muramatsu, T. Onuma, T. Sawada, A. Shimizu, M. Uchida, R.G.T.

Zegers

Department of Physics, Pusan National University : J.K. Ahn, J.Y. Park

School of Physics, Seoul National University : H.C. Bhang, K.H. Tshoo

Department of Physics, Konan University : H. Akimune

Japan Atomic Energy Research Institute / SPRING-8 : Y. Asano, A. Titov

Institute of Physics, Academia Sinica : W.C. Chang, D.S. Oshuev,

Japan Synchrotron Radiation Research Institute (JASRI) / SPRING-8 : H. Ejiri, S. Date', N. Kumagai,
Y. Ohashi, H. Ohkuma, H. Toyokawa, T. Yorita

Department of Physics and Astronomy, Ohio University : K. Hicks, T. Mibe

Department of Physics, Kyoto University : K. Imai, H. Fujimura, T. Miwa, M. Miyabe, Y. Nakatsugawa,
M. Niiyama, N. Saito, M. Yosoi

Department of Physics, Chiba University : H. Kawai, T. Ooba, Y. Shiino

Wakayama Medical University : S. Makino

Department of Physics and Astrophysics, Nagoya University : S. Fukui

Department of Physics, Yamagata University : T. Iwata

Department of Physics, Osaka University : S. Ajimura, M. Nomachi, A. Sakaguchi, S. Shimizu, Y. Sugaya

Department of Physics and Engineering Physics, University of Saskatchewan : C. Rangacharyulu

Department of Physics, Tohoku University : M. Sumihama

Laboratory of Nuclear Science, Tohoku University : T. Ishikawa, H. Shimizu

Department of Applied Physics, Miyazaki University : T. Matsuda, Y. Toi

Institute for Protein Research, Osaka University : M. Yoshimura

National Defense Academy in Japan : T. Matsumura



Characteristics of LEPS photons

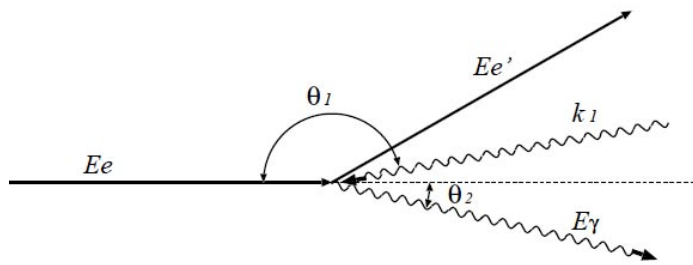

- rather flat energy distribution with small spreading \rightarrow clean GeV γ

(Unlike the Bremsstrahlung, where low energy photons are dominated, $\sim 1/E_\gamma$)

- high linear- or circular-polarization
- photon energy can be tagged by recoil electron

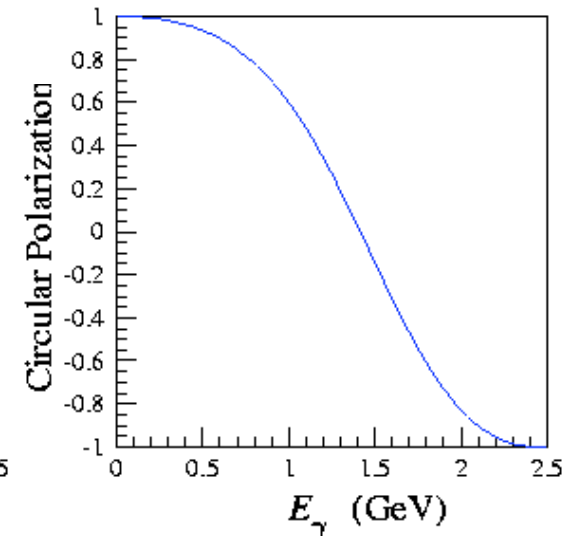
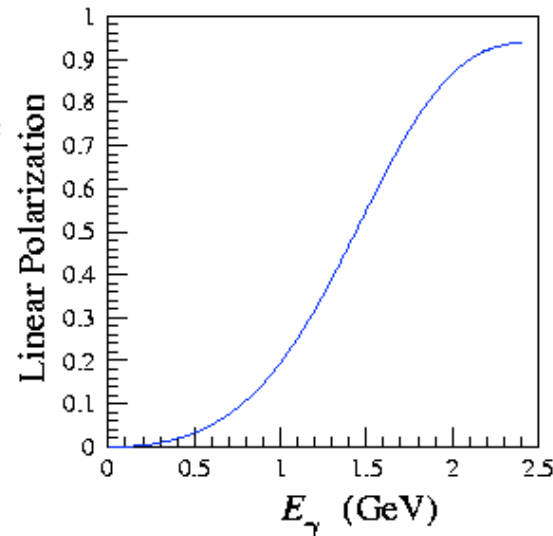
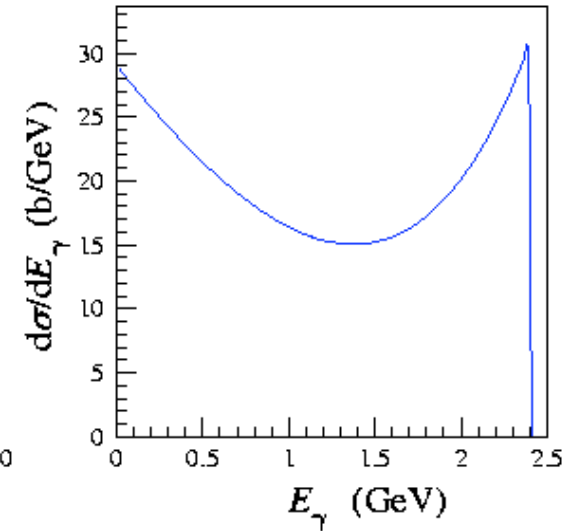
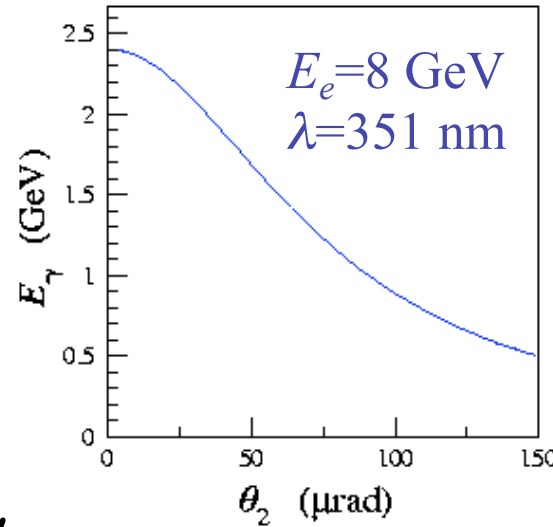



What can be produced with LEPS?

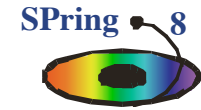

Photoproduction Threshold

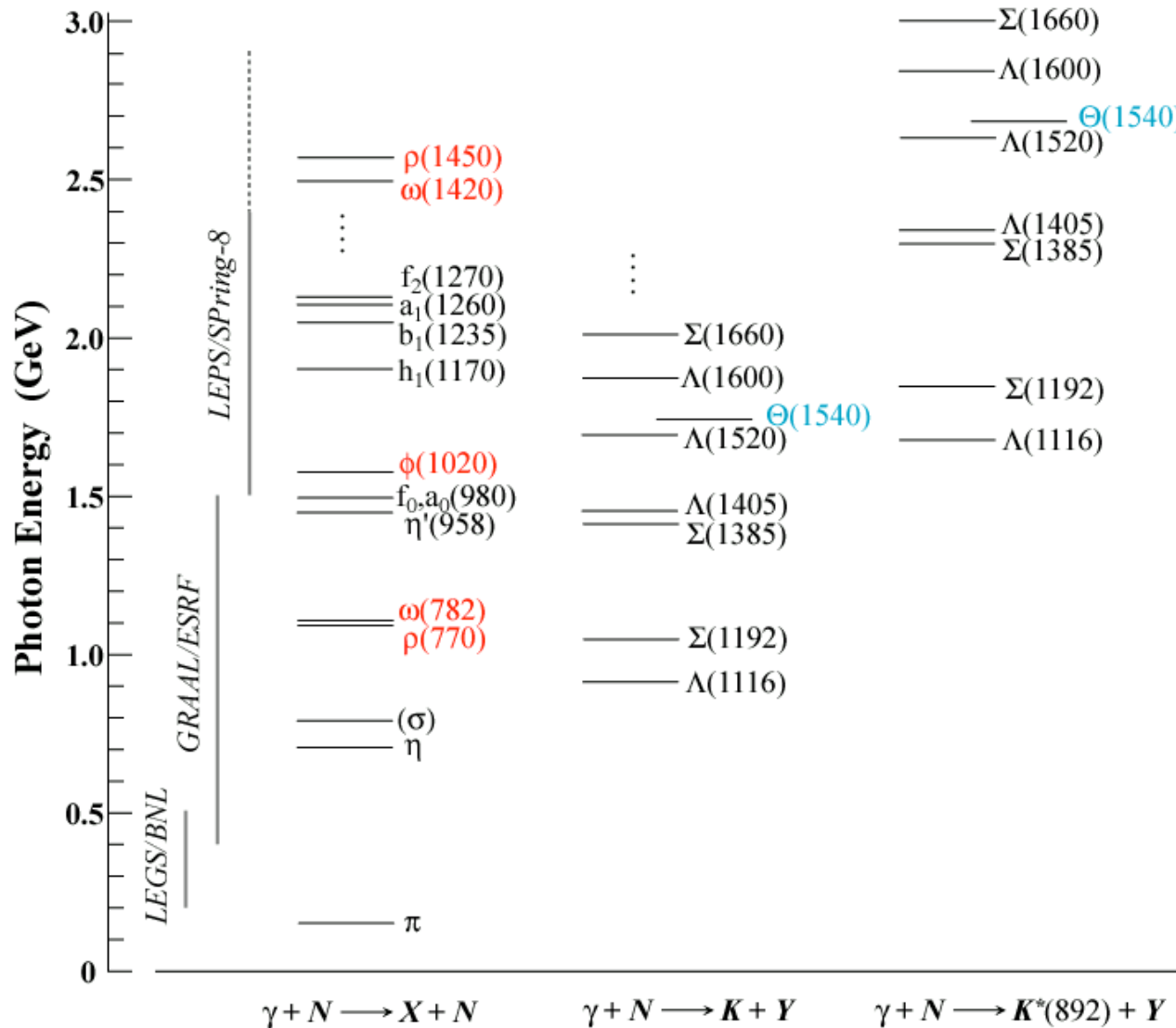

Threshold region of $\phi(s\bar{s})$ meson and hyperon resonances

Key words :

1. Forward angle measurement including 0 deg.
2. Polarization observables
3. Strangeness



LEPS forward spectrometer

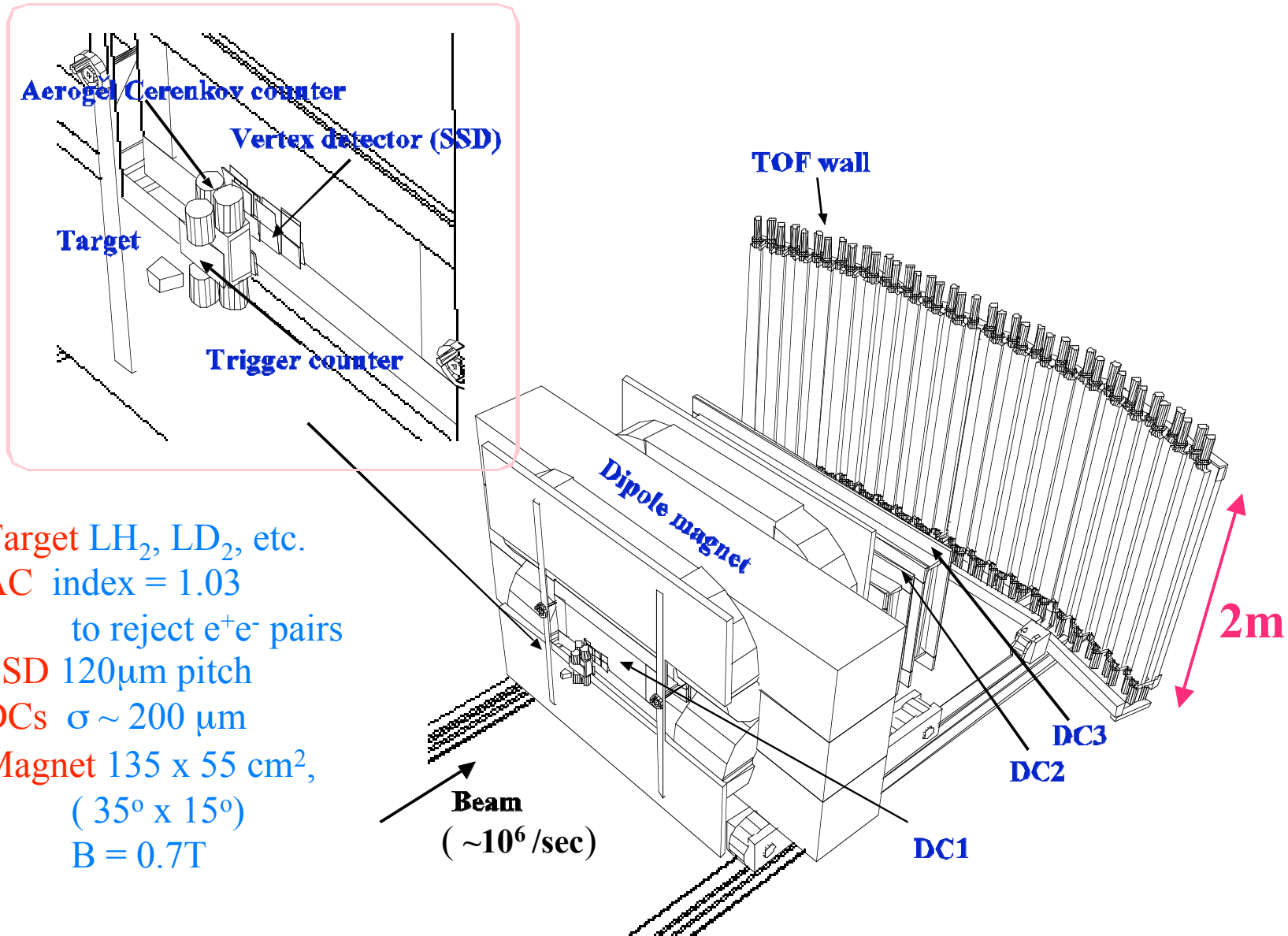
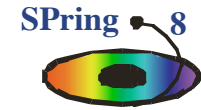

- Target LH_2 , LD_2 , etc.
- AC index = 1.03
to reject e^+e^- pairs
- SSD 120 μm pitch
- DCs $\sigma \sim 200 \mu\text{m}$
- Magnet 135 x 55 cm^2 ,
(35° x 15°)
B = 0.7T



EM calorimeter for $\pi^0 \rightarrow 2\gamma$, $\eta \rightarrow 2\gamma$

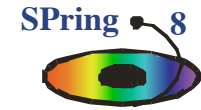

- Main detector
Lead scintillating fiber
252 modules
- Covered solid angle
2.08 π (str)
 θ : 30° ~ 100°
 ϕ : 0° ~ 360°
- Length of each module
22cm (13.7 X_0)
- Angular interval (segment)
10 degree

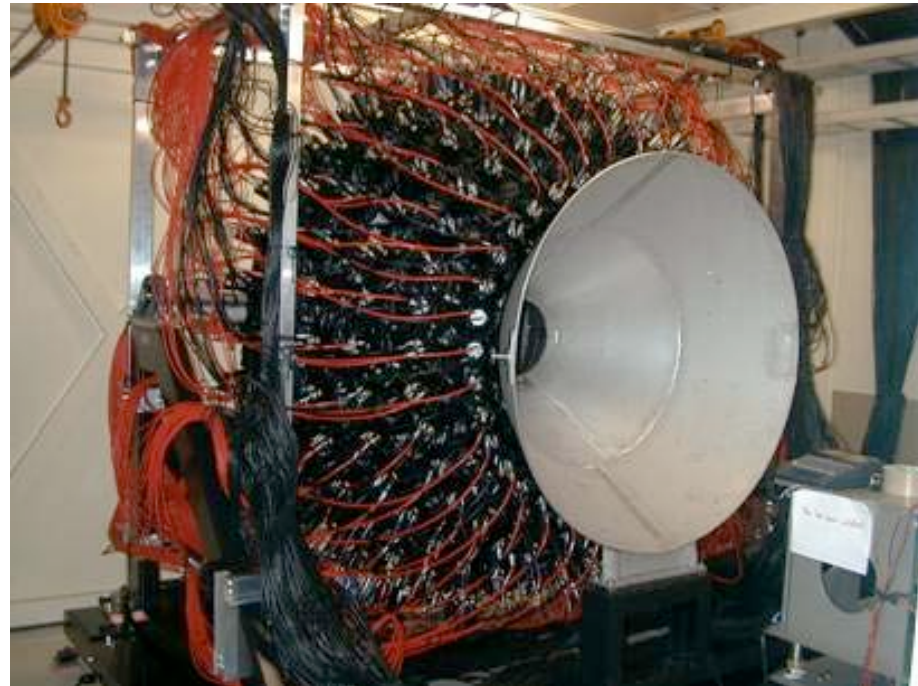

- Energy resolution

$$\frac{\sigma_E}{E} = \sqrt{\left(\frac{5.2 \pm 0.1\%}{\sqrt{E}}\right)^2 + (4.4 \pm 0.2\%)^2}$$

(6.8% for 1 GeV photon)



TPC for Hyperon Resonances

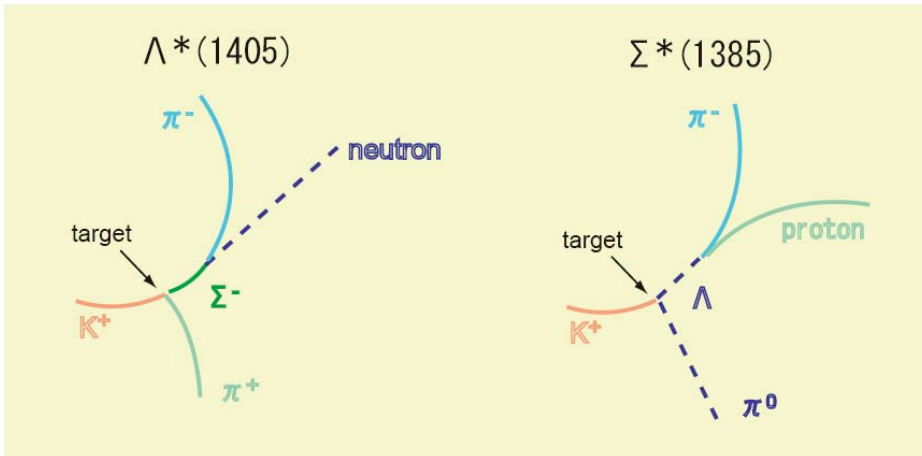

$\Lambda(1405)$: $3/2$ ——— $\Lambda(1520)$
 3-quark state
 or
 KN bound state ? $1/2$ $\begin{matrix} \text{---} KN \\ \updownarrow 30 \text{ MeV} \\ \text{---} \Lambda(1405) \end{matrix}$

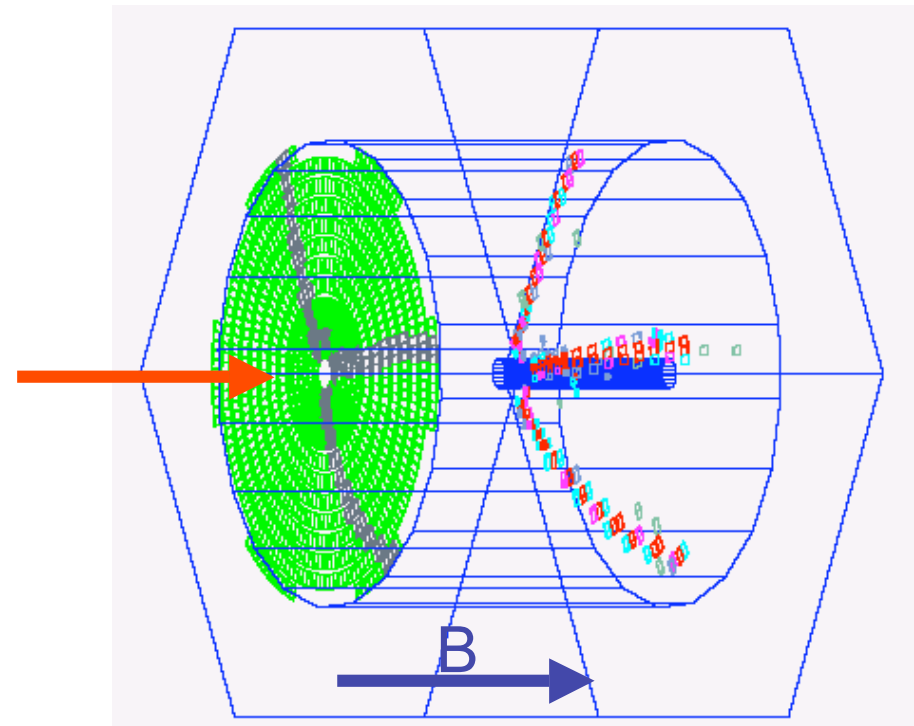
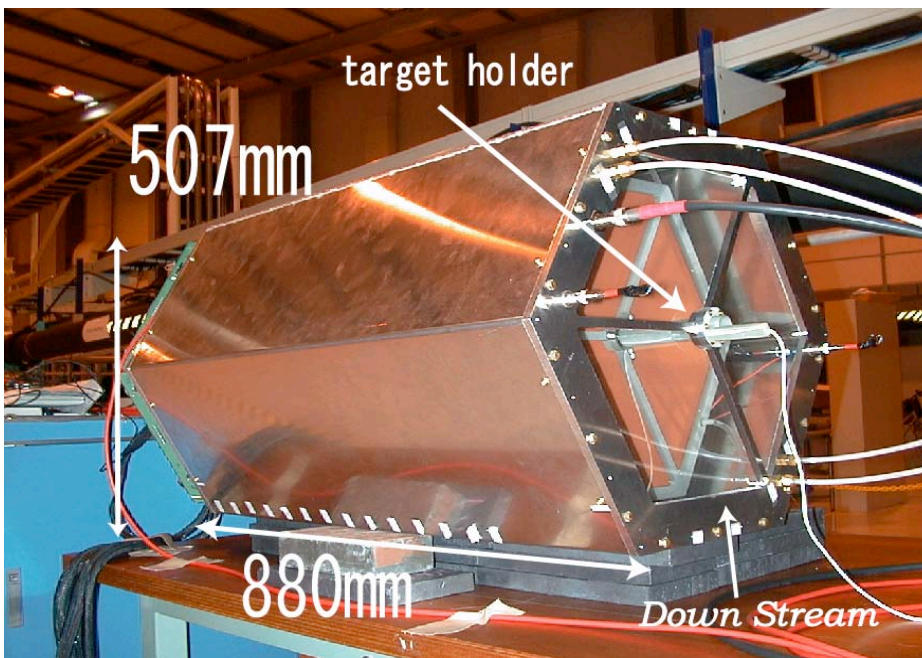



Experiments at LEPS



- Liq. H₂ tgt. (Dec. 2000~)
 ϕ photoproduction, $K^+ X$ [Λ , Σ , $\Lambda(1405)$]
- Liq. D₂ tgt.(Oct. 2002~)
 ϕ , $\rho(\gamma, \eta\pi^0)$ [γ detector], Θ^+ confirmation
- Nuclear tgt. + TPC (Apr. 2004~)
 $\Lambda(1405)$



Identification of Θ^+

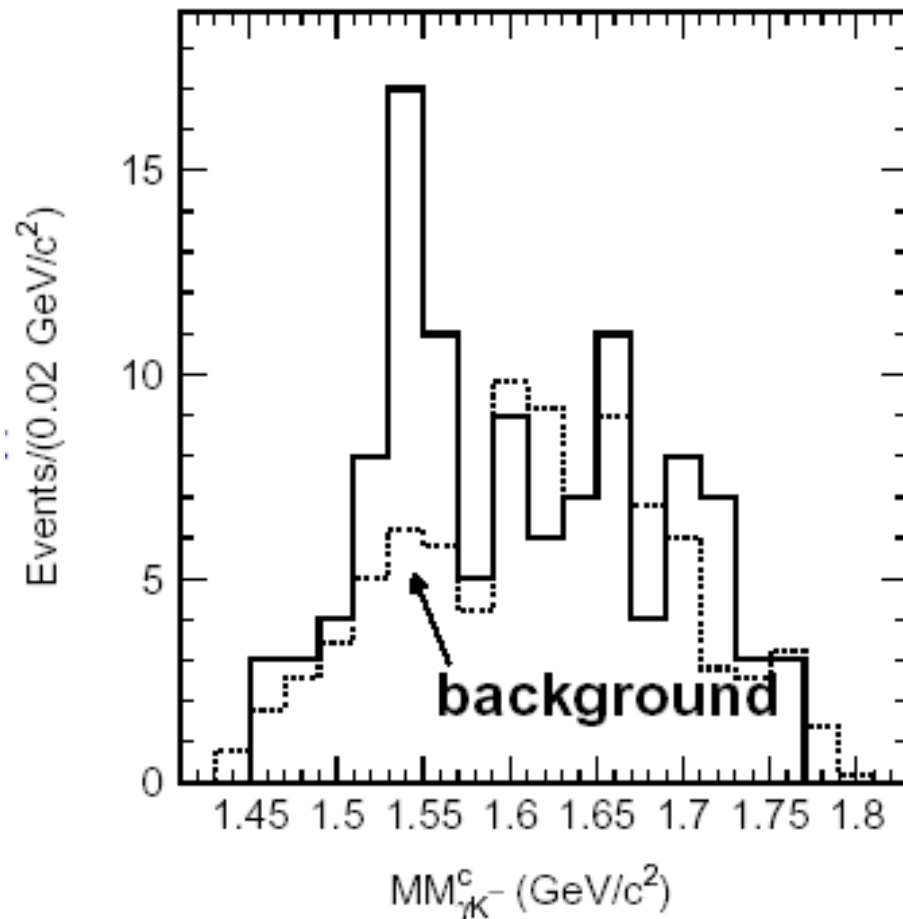
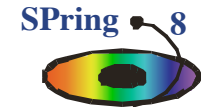

- $M = 1.54 \pm 0.01$ GeV
- $\Gamma < 25$ MeV
- Gaussian significance
 - 4.6σ
 - PRL 91(2003)012002



Further Searches for Θ^+



Urgent experimental issues:

- Confirmation of the existence
- Spin, parity
- Width
- Partners

Currently under the working:

- Search for Θ^+ in $\gamma n \rightarrow K^+ K^- n$ (with an order higher statistics)
- Θ^+ search in $\gamma d \rightarrow \Lambda(1520) KN$ reaction

In the near future,

- $\gamma p \rightarrow \bar{K}^* \Theta^+$ \Leftarrow energy upgrade to 3.4 GeV



ϕ photoproduction from the proton



T. Mibe et. al., PRL 95, 182001 (2005)

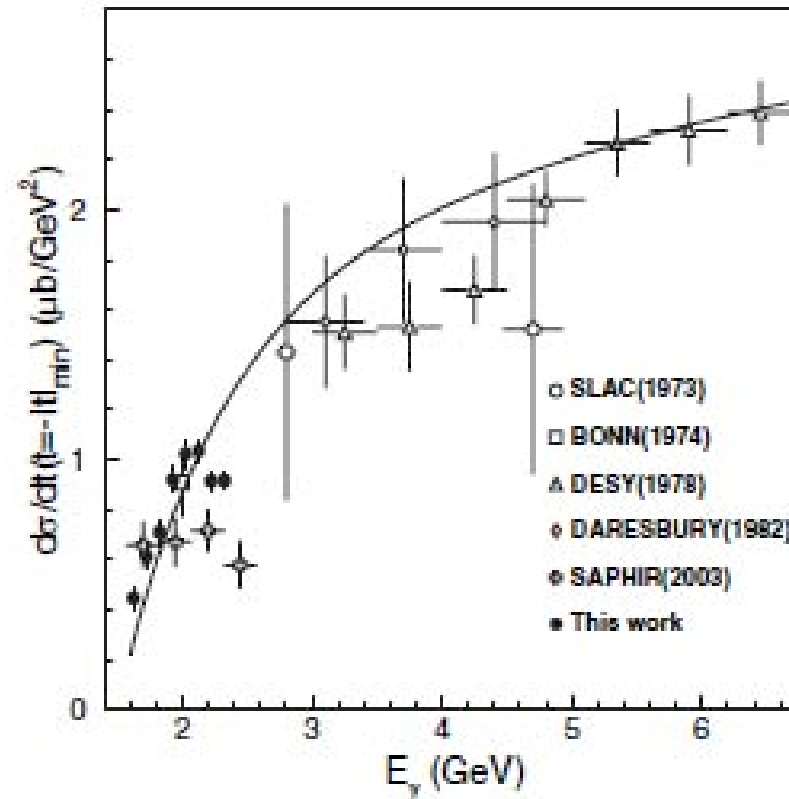



LEPS in the future



We have just started to discuss the possibility and conceptual design for the new (2nd) LEPS BL.

- **Beam upgrade**

Energy --- Laser with short λ , **Soft X-ray+BCS**, Compact accelerator,

Intensity --- High power laser, **LRNB** $10^6 \rightarrow 10^7-10^8$ /sec ?

Quality --- Round beam

- **Detector upgrade**

Scale --- General purpose 4π detector

Flexibility --- Coincidence measurement of charged particles and neutral particles (including γ)

DAQ --- High speed for the minimum bias trigger

- **New physics**

Workshop on LEPS new beamline (7/28,29 2005)



High Energy Backward Compton Photons

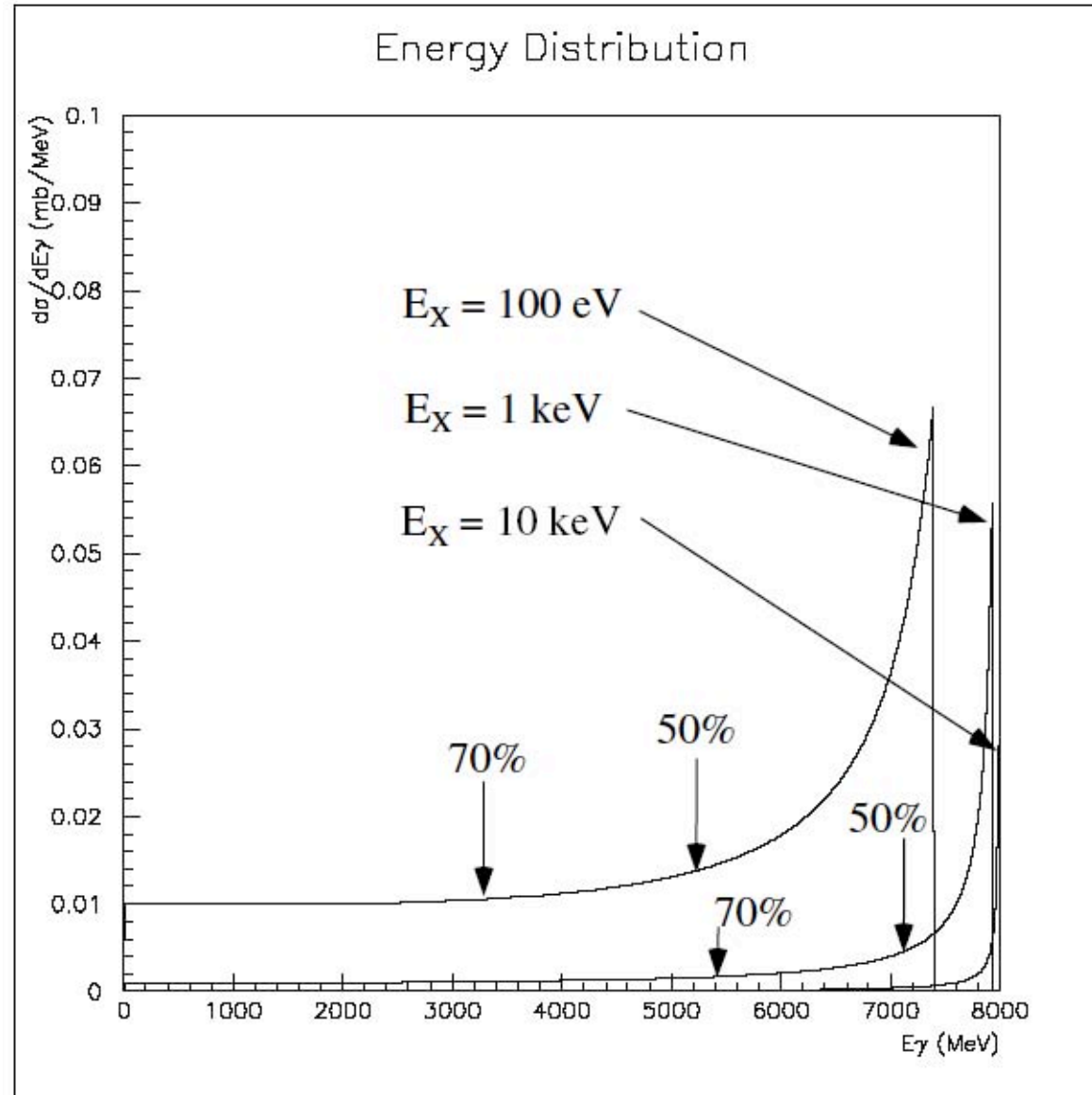



HLEP generation by reinjection of X-rays



C Rho=3.5, Sig=0.nm, P=1., 10.deg

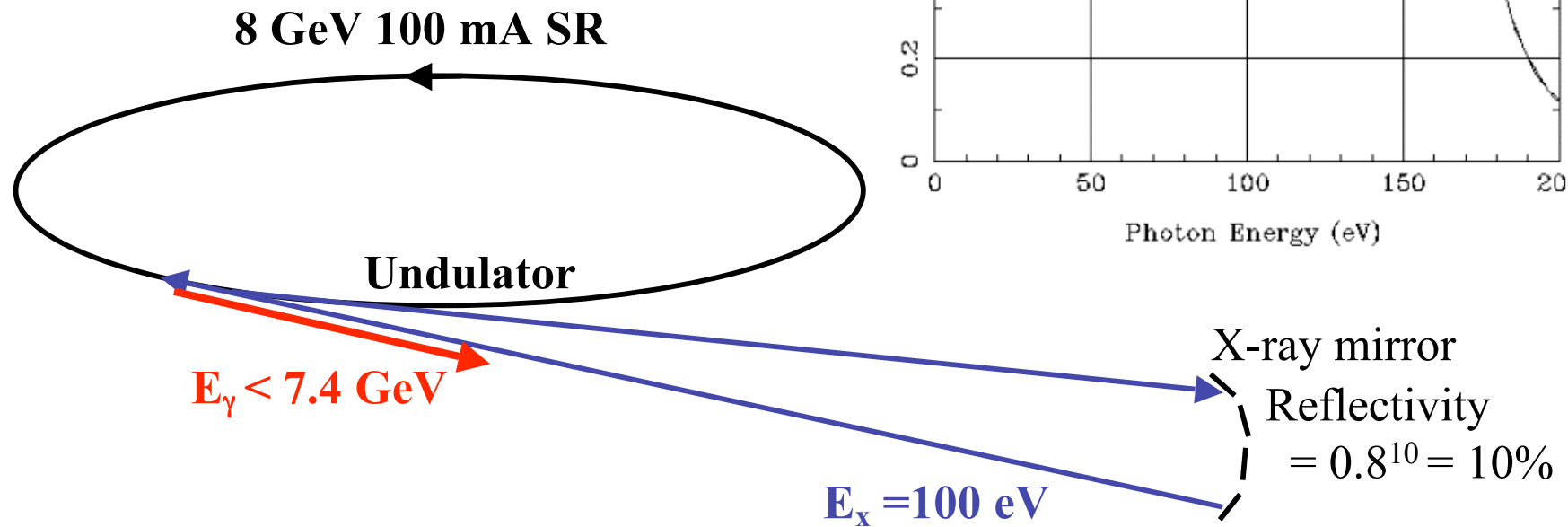
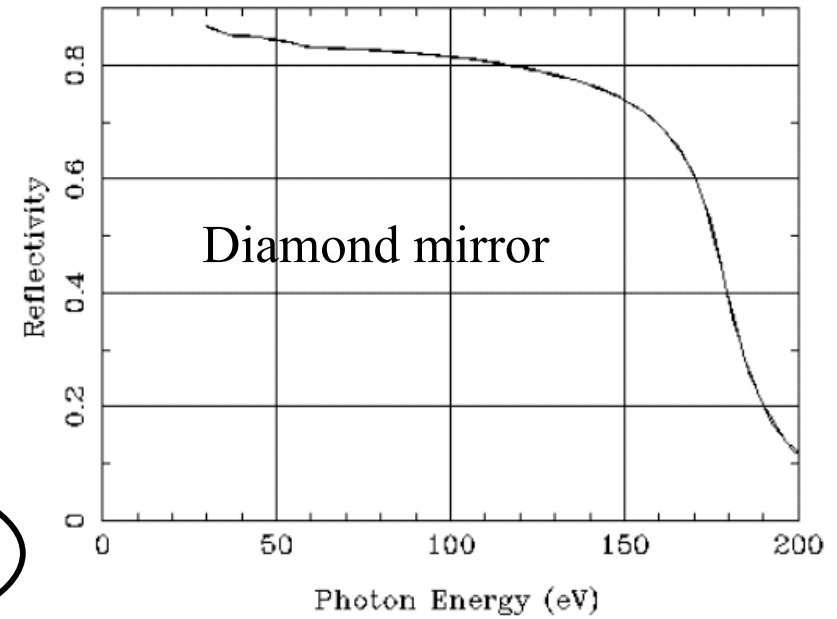



Summary on the LEPS BL

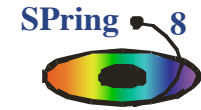

- LEPS is generating 10^6 s^{-1} 2.4 GeV photons for quark nuclear physics.
- Forward spectrometer experiments discovered the Θ^+ paek.
- Many other interesting topics in hadron physics are studied in the LEPS BL.
- Energy upgrade to 2.9 GeV is on the schedule.
- Further upgrade of energy, first to 3.4 GeV, is under the discussion.
- We have started to discuss the possibility to construct a new LEPS BL with upgrades in energy, intensity and detectors. Generation of several GeV photons is in the scope of the discussion.



LEPS homepages

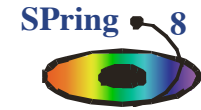

If you are interested in LEPS, please visit us at

<http://www.spring8.or.jp/e/bl/BL33LEP/index.html>

<http://www.rcnp.osaka-u.ac.jp/Divisions/np1-b/index.html>

Production of 10 MeV γ -ray by the Backward Compton Scattering Using an Optically-Pumped FIR Laser at SPring-8

• H. Ohkuma, Y. Arimoto¹, K. Kawase², K. Tamura, S. Suzuki, T. Yorita, M. Shoji, M. Fujiwara² and S. Okajima³

JASRI/SPring-8, ¹Department of Physics, Osaka University

²RCNP, Osaka University, ³College of Engineering, Chubu University

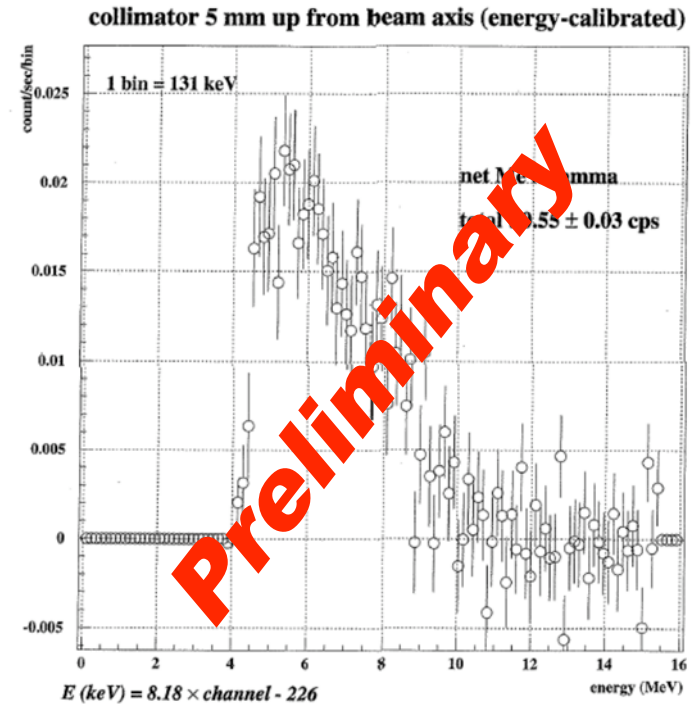
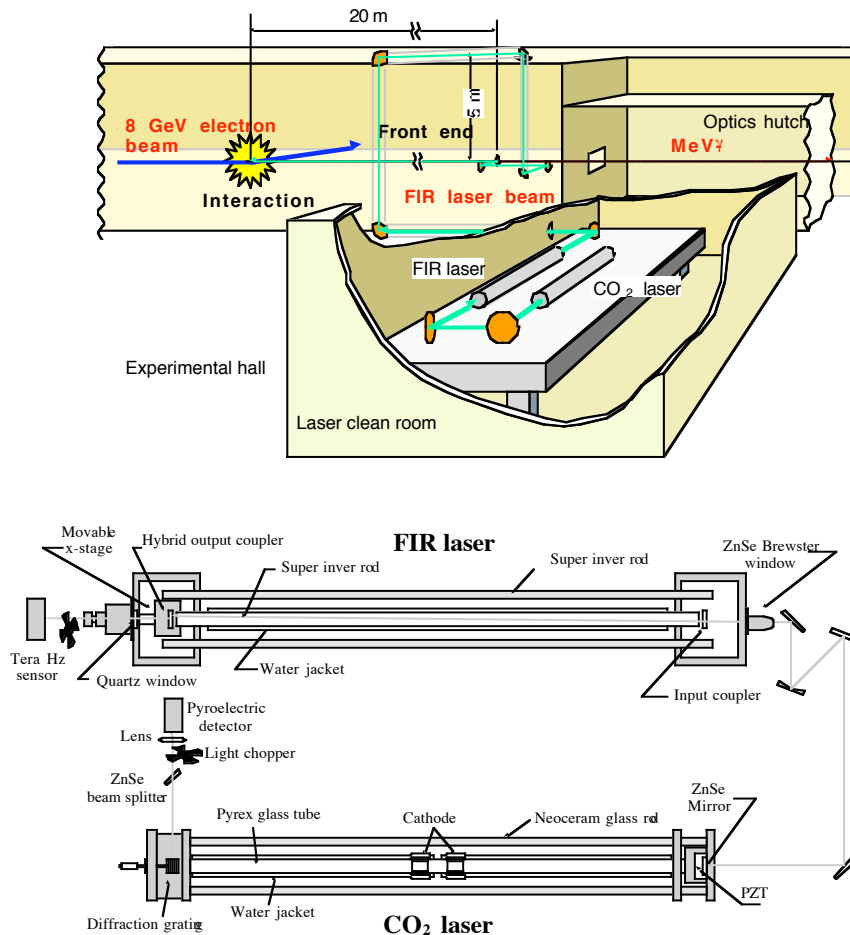

Laser-backscattered γ -ray source@ NewSUBARU

